

TRAVEL = 565±2

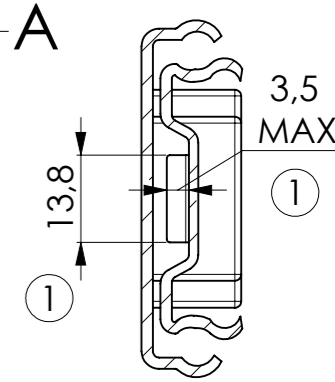

DETTAGLIO K  
SCALA 2:1

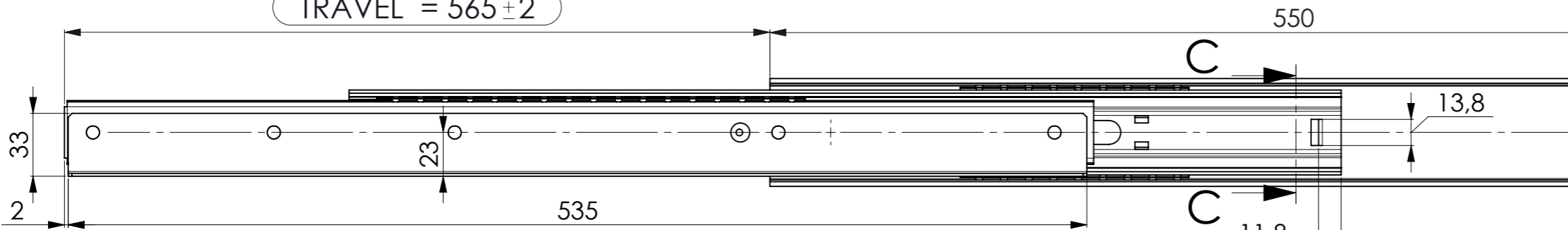
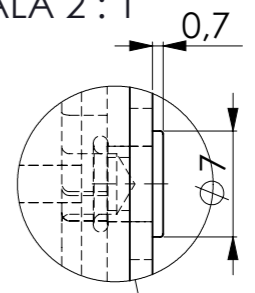

SCALA 1:1

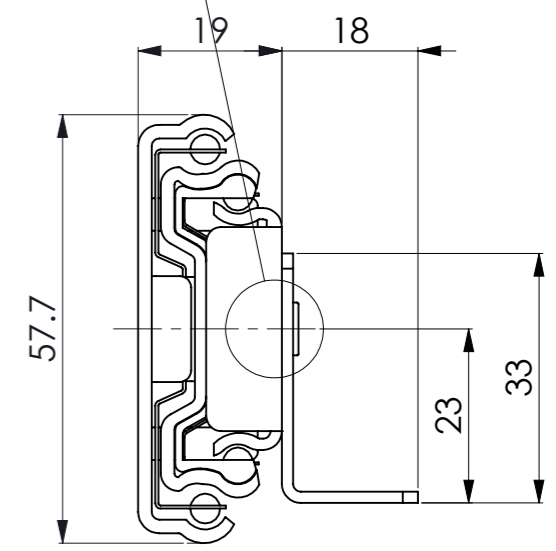

LA GUIDA RAPPRESENTATA E QUOTATA E' LA SX:  
LA GUIDA DESTRA E' SPECULARE  
THE SLIDE SHOWN (WITH DIMENSIONS) IS THE LH ONE:  
THE RH SLIDE IS REVERSED

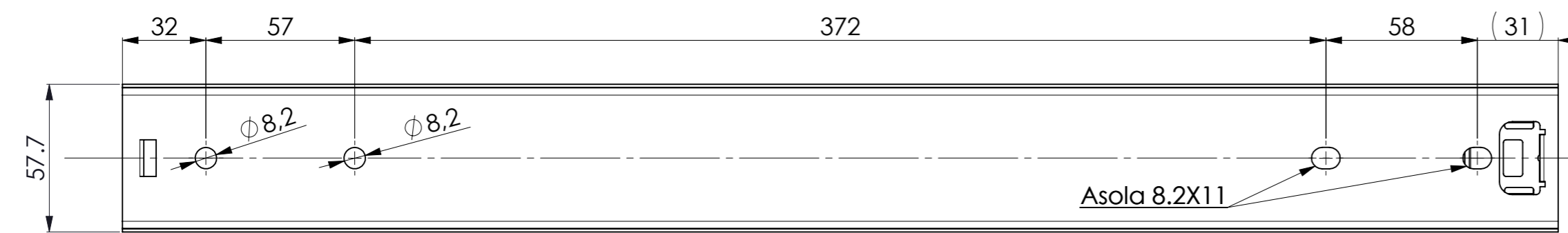
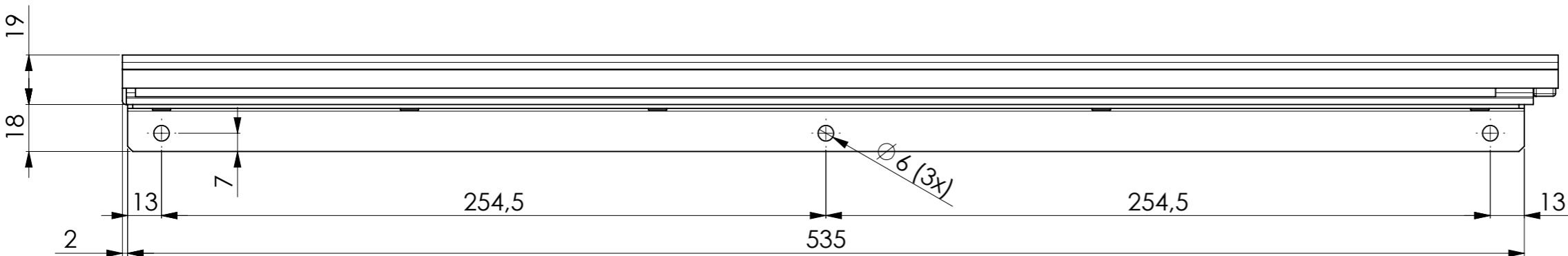
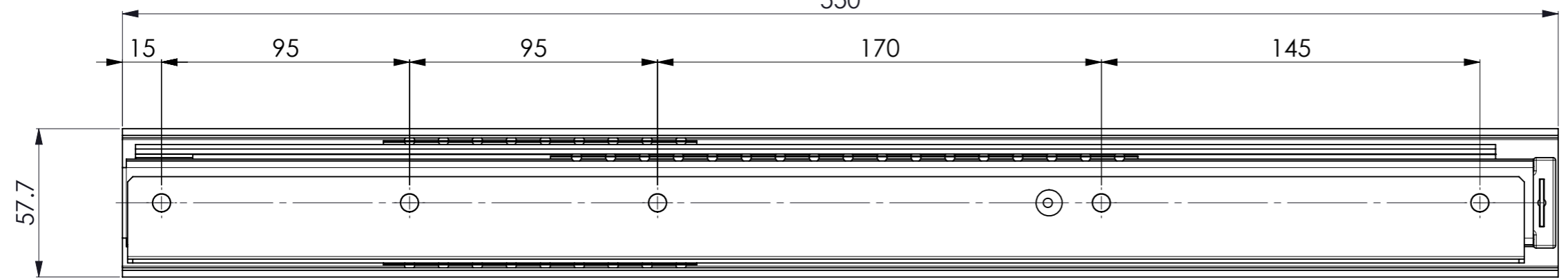

Asola 8.2X11

DETTAGLIO A  
SCALA 1:1.5

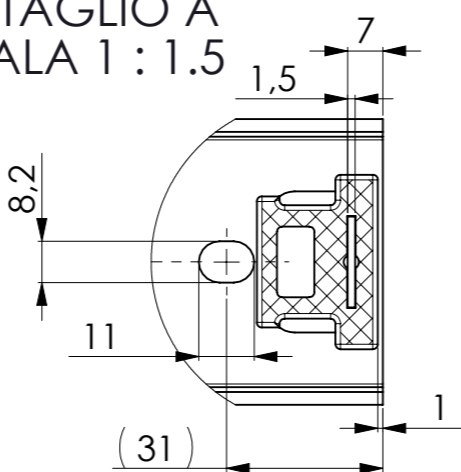

SCALA 1:5

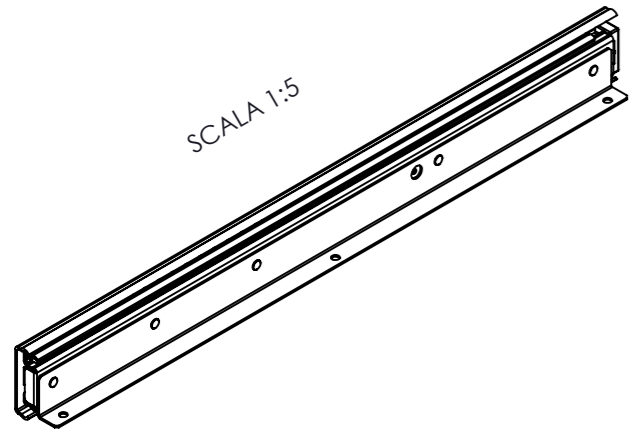

REV. 1	DATA: 29-7-13	OPERATORE: C.M.	DESCRIZIONE MODIFICA: MODIFICATO ARRESTO GUIDA SEZ C-C ①												
SCOSTAMENTI PER QUOTE SENZA INDICAZIONE DI TOLLERANZA EN 22768-1		RACCORDI NON QUOTATI=1 SMUSSI NON QUOTATI=1x45° ANGOLI: ±0°30'													
DIMENSIONI (mm)	Da 0 a 6	>6 a 30	>30 a 120	>120 a 315	>315 a 1000	>1000 a 2000	>2000 a 4000	oltre 4000	COMPARAZIONE VALORI DI RUGOSITA'						
FINE	±0.02	±0.05	±0.06	±0.08	±0.1	±0.2	±0.3	±0.5	√ = √	▽ = 6.3/ MAX	▽ = 3.2/ MAX	▽ = 1.6/ MAX	▽ = 0.8/	▽ = 0.2/	⊕
MEDIO	±0.1	±0.2	±0.3	±0.5	±0.8	±1.2	±2	±3							
GROSS.	±0.2	±0.5	±0.8	±1.2	±2	±3	±4	±6							
DISEGNO RISERVATO A NORMA DI LEGGE; è VIETATO RIPRODURLO O DIVULGARLO SENZA AUTORIZZAZIONE.															
SERA:			DESCRIZIONE: CP.GUIDE SFERA ESTR TOT L=550mm C=565mm CON STAFFA L=535 - ZINCATE												
COMMITTENTE: MS			MATERIALE: Fe360 TRATTAMENTO SUPERFICIALE: ZINCATURA												
DISEGNATORE: Carlo M.		DATA: 08/10/12		SCALA: 1:2		MODELLO: T57		CODICE ARTICOLO: T57SI55-565ZMS		QTA':		DISEGNO: 002179-1			