

# SP-SL-116

## Sponde Metalliche SLIM – H.116

SLIM Metal Boxes – H.116

### Specifiche/Specifications

Estrazione/Extension: **Totale Sincronizzata**/Full Synchronized

Chiusura/Closing: **Ammortizzata**/Soft

Portata/Load rating: **45 Kg** (450 mm as standard)

Durata/Cycling: over 50000 times

Finitura Guida/Slide Finishing: **Zincata**/Galvanized

Finitura Sponda/Slim Box Finishing:

Grigio Antracite / Dark Grey
  Grigio Chiaro / Light Grey
  Bianco / White

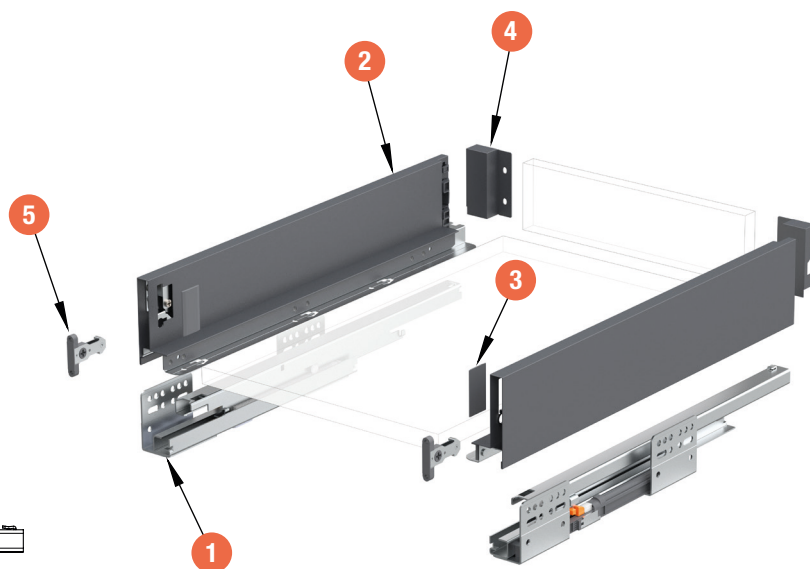
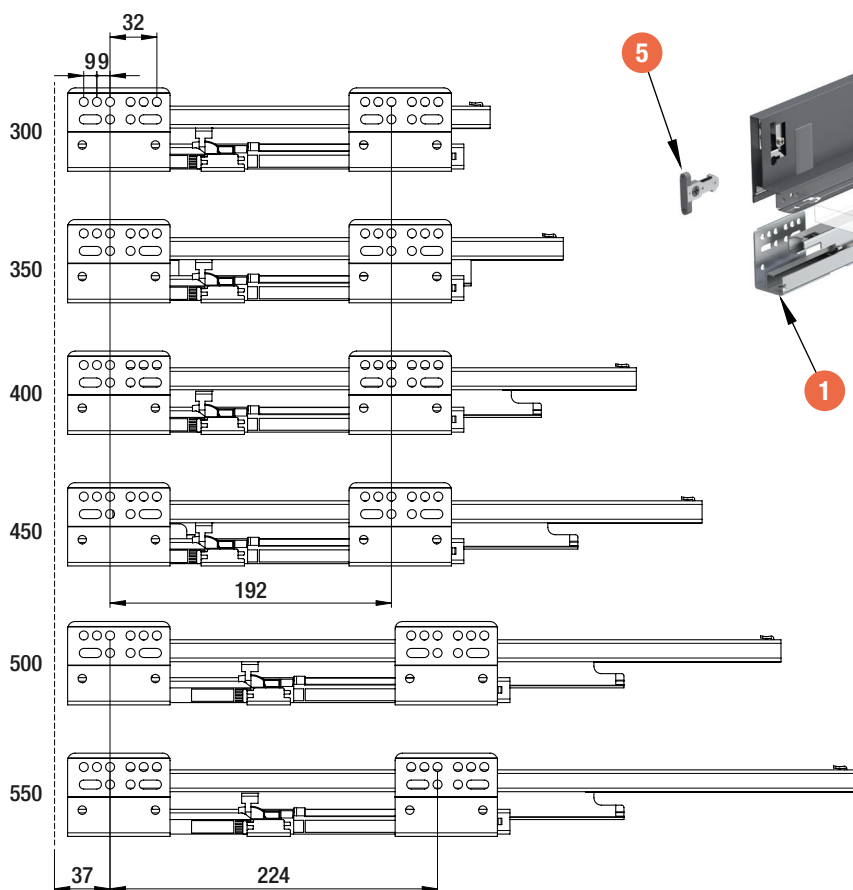

### Componenti/Components

- 1 - Guide/Slides
- 2 - Sponde/Slim Boxes
- 3 - Placchette/Covers
- 4 - Supporti Retro/Black Panel Supports
- 5 - Supporto Frontale/Front Panel Supports

### Dimensioni per montaggio frontale

Drawer front assembling diagram

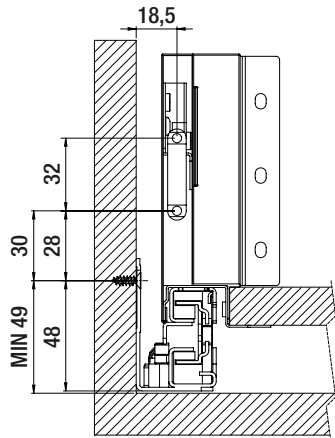

Vista frontale / Front view

### Dimensioni ingombro cassetto e retro

Drawer and back panel overall dimensions

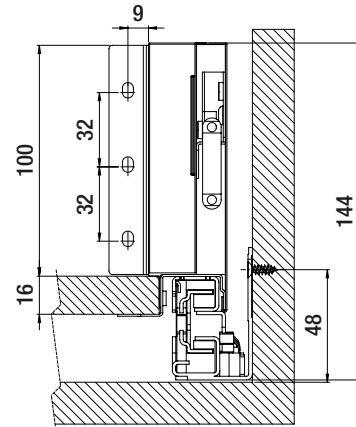

Vista retro / Back view

### Dimensioni fondo e retro

Bottom and back panel dimensions

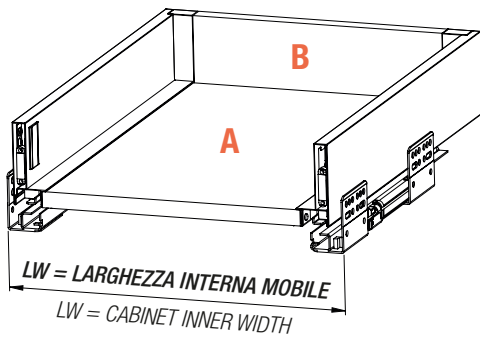

Fondo / Bottom panel

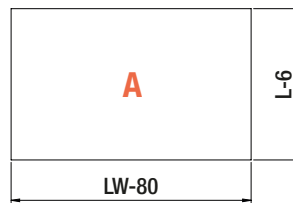

Retro / Back panel

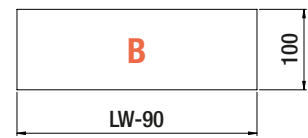

Pannello spessore 16mm / Panel thickness: 16 mm

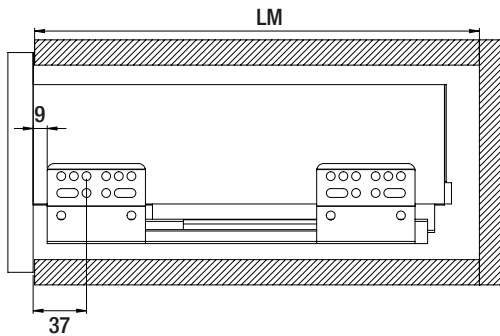

Foratura fianco con frontale a battuta  
Side panel hole drilling with outer drawer front

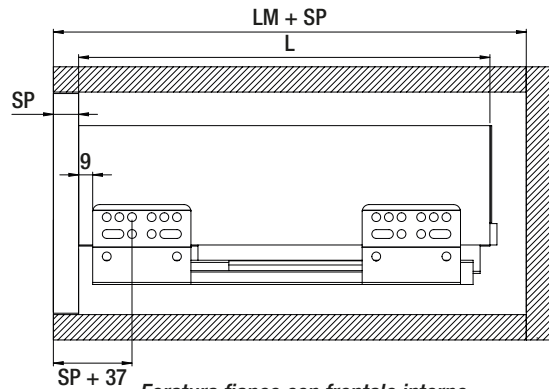

Foratura fianco con frontale interno  
Side panel hole drilling with inner drawer front

Codice/Code				L	LM
SP-SL-116 L 30 -	GA	GC	B	300	310
SP-SL-116 L 35 -	GA	GC	B	350	360
SP-SL-116 L 40 -	GA	GC	B	400	410
SP-SL-116 L 45 -	GA	GC	B	450	460
SP-SL-116 L 50 -	GA	GC	B	500	510
SP-SL-116 L 55 -	GA	GC	B	550	560