

DL

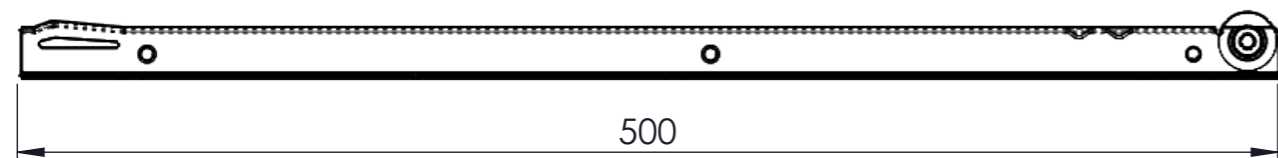

DR

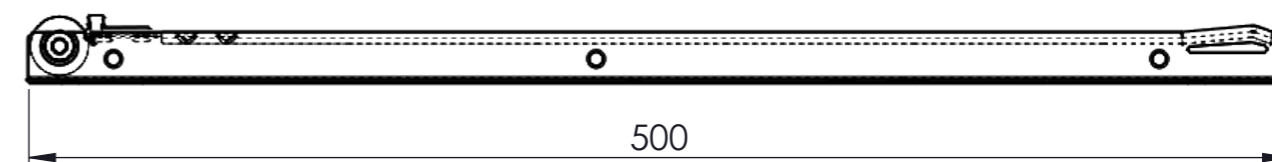

CL

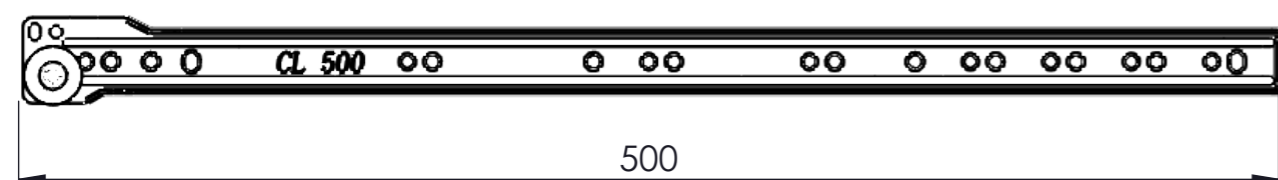

CR

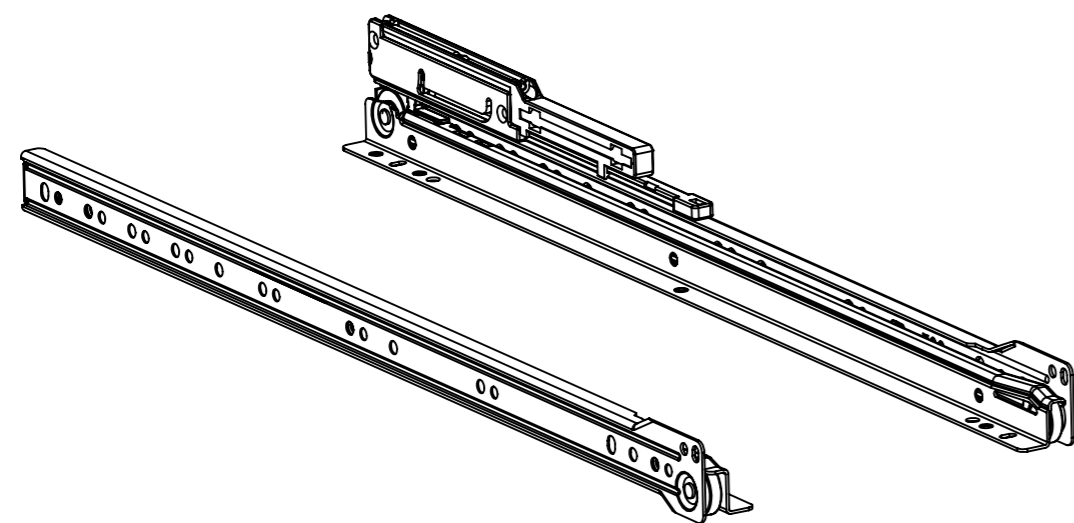
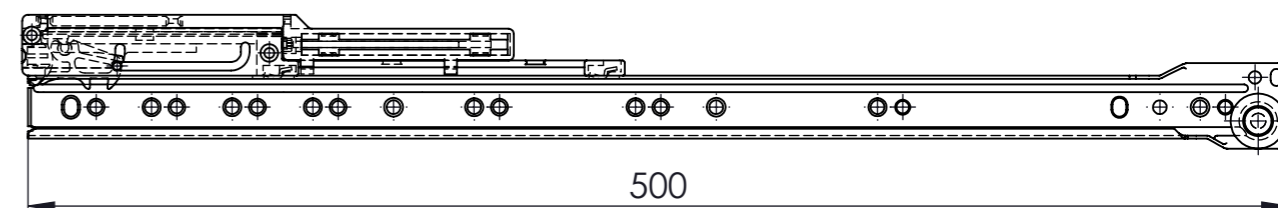

DISEGNO	DESCRIZIONE	CODICE	SIGLA
003020-0	GUIDA A RULLO F62 L500 DL NERA	F62-LS50-N-DL	DL
003021-0	GUIDA A RULLO F62 L500 DR NERA	F62-LS50-N-DR	DR
003022-0	GUIDA A RULLO F6 L500 CL NERA	F6-LS50-N-CL	CL
003023-0	GUIDA A RULLO F6 L500 CR NERA	F6-LS50-N-CR	CR

REV.	DATE:	OPERATOR:	CHANGE DESCRIPTION:
DIMENSIONS WITHOUT SPECIFIED TOLERANCE UNI EN ISO 22768-1			ROUGHNESS VALUES COMPARISON
DIMENSION (mm)	> 0 To 6	> 6 To 30	> 30 To 120
MEDIUM	±0,1	±0,2	±0,3
	> 120 To 315	> 315 To 1000	> 1000 To 2000
	±0,5	±0,8	±1,2
	> 2000 To 4000	> 4000	
	±2	±3	
DESCRIPTION: COMPLESSIVO GUIDE F62 L=500			NOTE: * Processing not required by the customer Lavorazione non richiesta dal cliente
MATERIAL: Fe 360		SURFACE TREATMENT: VERNICIATURA	
DESIGNER: MANUEL	DATE: 26/10/2017	SCALE: 1:3	ITEM NUMBER: ---
Sede Legale e Produzione - Pesaro Tel. +39 0721 403930 Fax. +39 0721 404025		DRAWING NUMBER: 003019-0	
Sede Produzione - Crevalcore (BO) Tel. +39 051 983344 Fax. +39 051 982844		G:\QS_RETE\DB\005\036\	
The reproduction and disclosure of this document is prohibited. Unauthorized use constitutes a crime under the prevailing law.			